

USTI 12 MFB 150 A-IBSL

Ultrasonic Sensor

- Analog output: increasing/decreasing, teachable
- Small design
- Scanning does not depend on surface
- Narrow detection beam / small blind zone

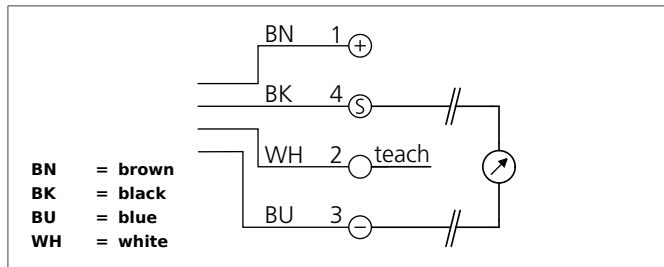

Safety instructions

The Instruments are not to be used for safety applications, in particular applications in which safety of persons depends on proper operation of the instruments.
These instruments shall exclusively be used by qualified personnel.

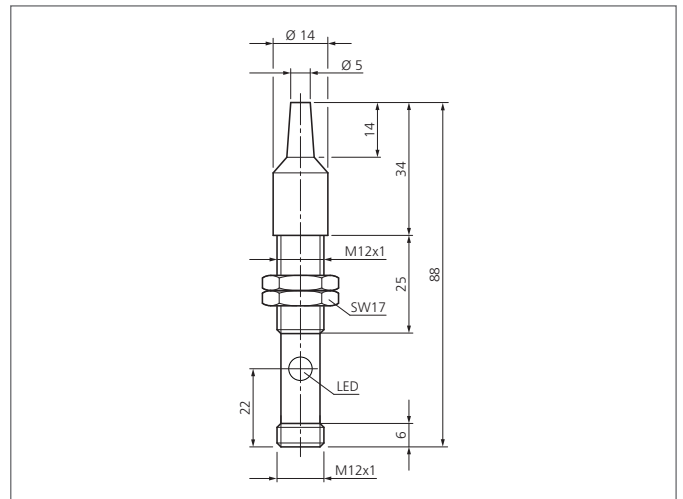

TECHNICAL INFORMATION (typ.)	+20°C, 24V DC
Operating principle	Ultrasonic sensor
Evaluation	analog
Size	M12 x 1 (thread)
Design	screw
Service voltage	15 ... 30 V DC
Internal power consumption	< 30 mA
Operating distance	20 ... 150 mm
Sensitivity adjustment	Remote teach
Analog output	0 ... 10 V
Operating frequency	400.000 Hz
Ripple	10 %
Linearity analog output	< 1 % / Sn max.
Ambient temperature	-25 ... +70 °C
Load resistance	< 1.000 Ω
Insulation voltage endurance	500 V
Protection class	IP 65
Casing material	brass nickel plated
Connection	Connector, M12, 4-poled